

DIP10° - 12° Inclined Passenger - Travelator Layout Drawing

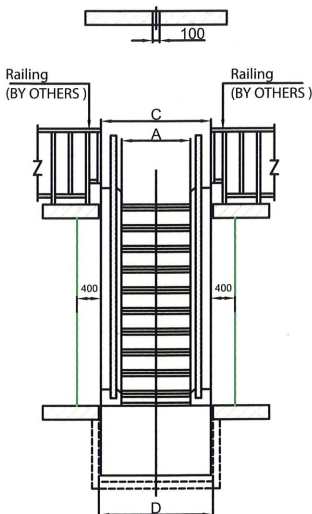
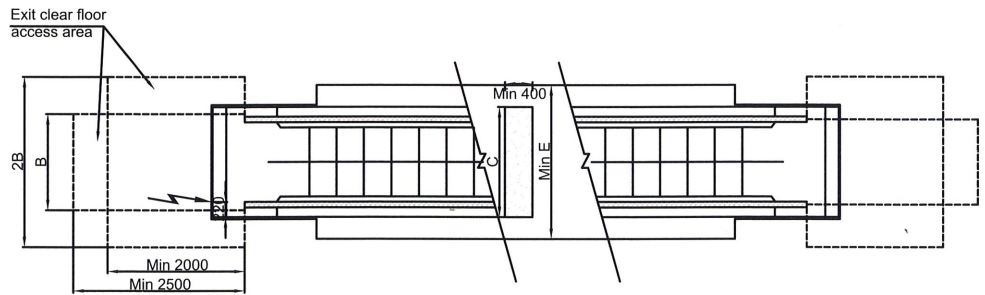
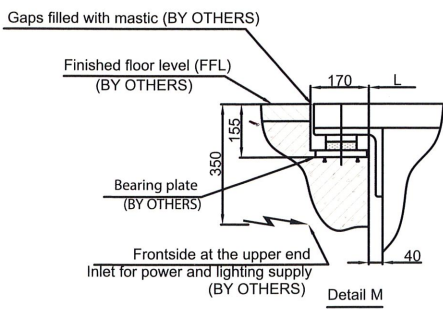
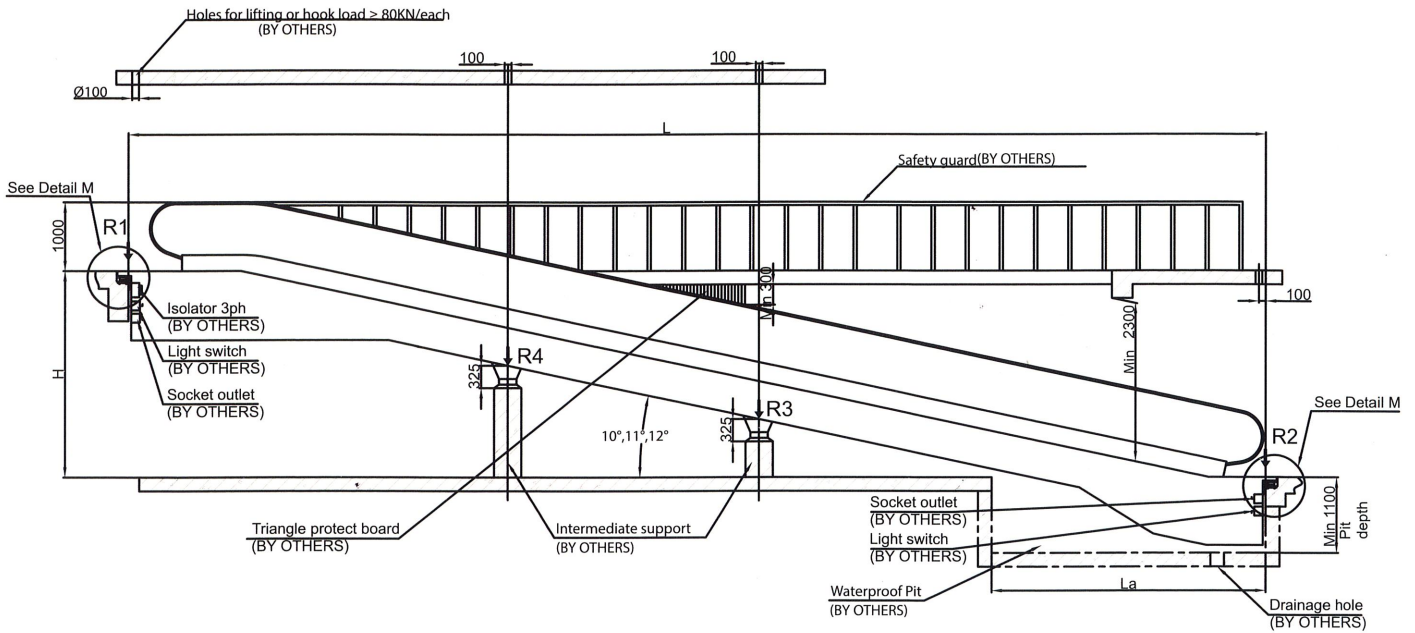

Type	A	B	C	D	E	K1	K2	Speed
DIP -800 4800 p/h	800	1350	1400	1460	2200	15000	30000	V=0.5m/s
DIP -1000 6000 p/h	1000	1550	1600	1660	2400	15000	30000	

Incline	10	11	12
L	Hx5.6713+2646	Hx5.1446+2550	Hx4.7046+2550
La	4650	4350	4050

As L>K1, one intermediate support is needed;
As L>K2, two intermediate support are needed;

Remarks:

1. There should be no water in the pit, and the surface of the pit should be smooth and flat.
2. The building support at both end of travelator should keep in level.
3. If the two travelators are put in parallel, the gap between the two travelators should not less than 10mm.
4. All dimension in mm.